

TYPE A

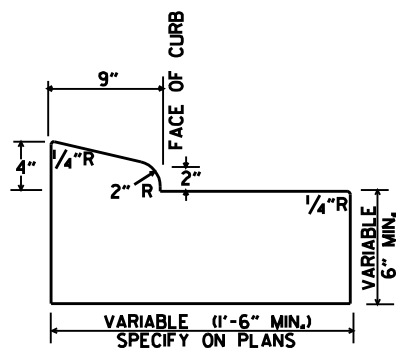

TYPE B-1

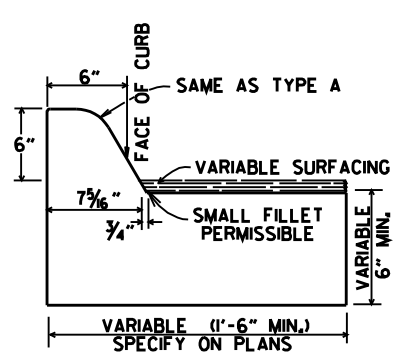

TYPE C

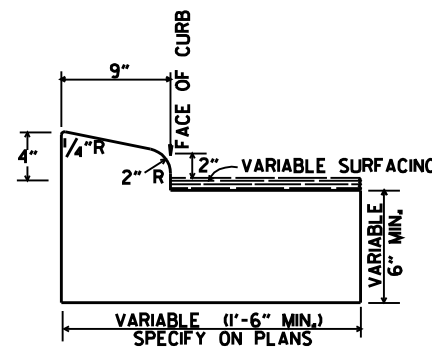

TYPE B-2

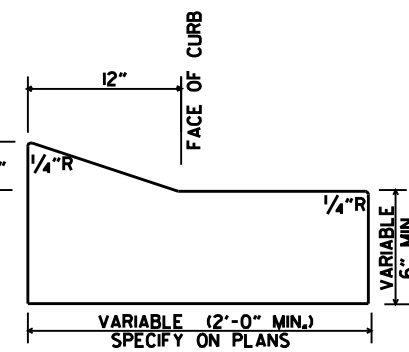

TYPE E-1

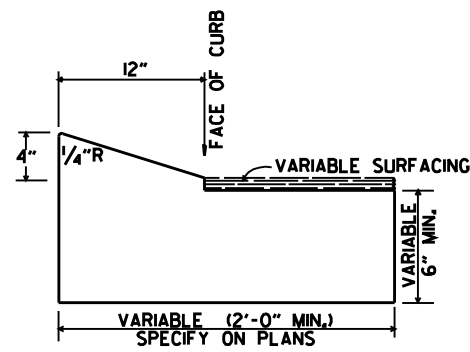

TYPE E-2

CONCRETE COMBINATION CURB AND GUTTER

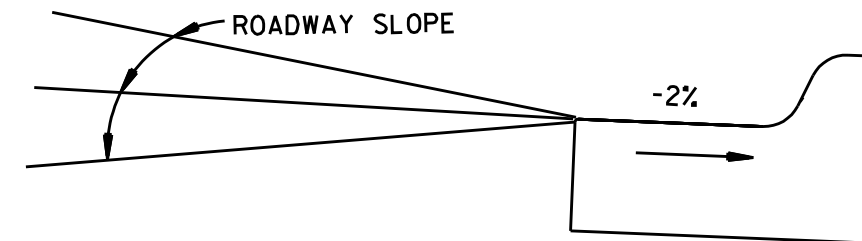

DETAIL OF GUTTER SLOPE
GUTTER SHALL BE CONSTRUCTED ON 2% SLOPE AWAY FROM ROADWAY, REGARDLESS OF ROADWAY SLOPE.

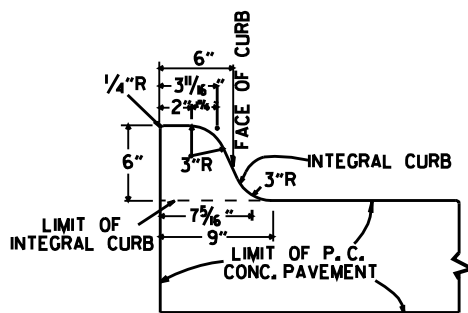

TYPE A

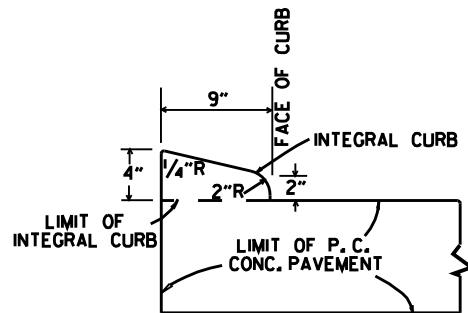

TYPE B

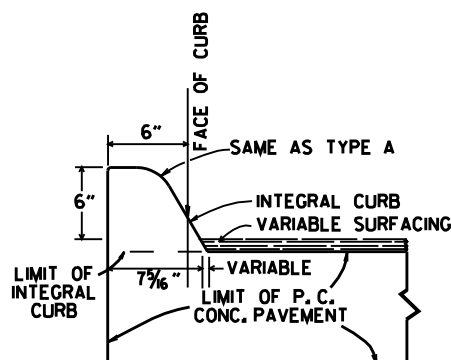

TYPE C

INTEGRAL CURB

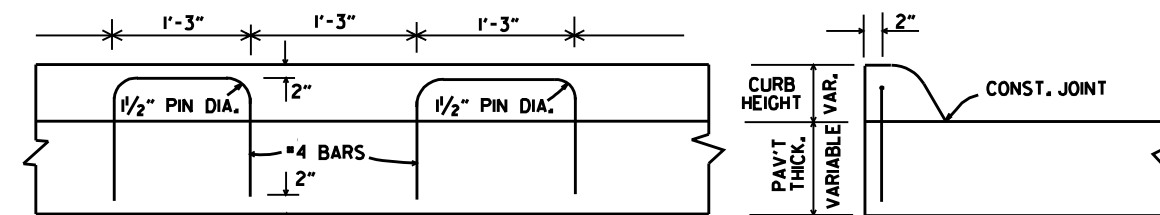

LONGITUDINAL SECTION

ELEVATION

ALTERNATE CONSTRUCTION METHOD FOR INTEGRAL CURB

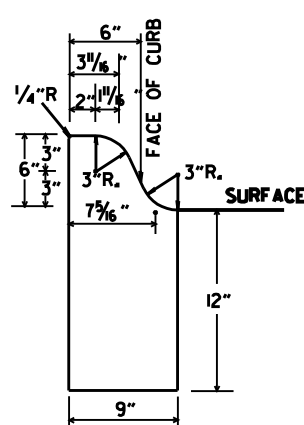

TYPE A

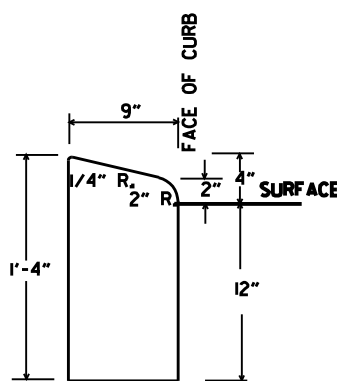

TYPE B

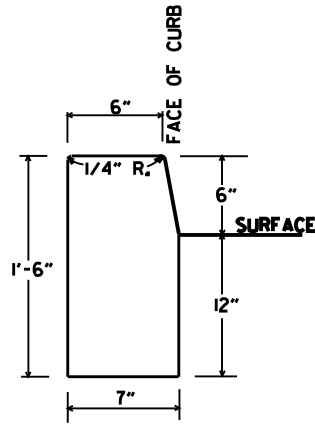

TYPE D

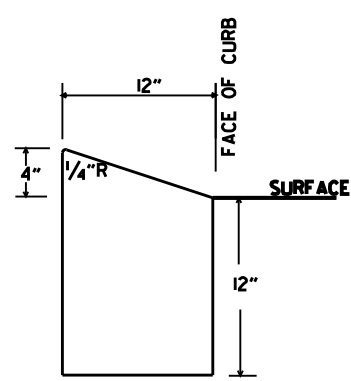

TYPE E

CONCRETE CURB

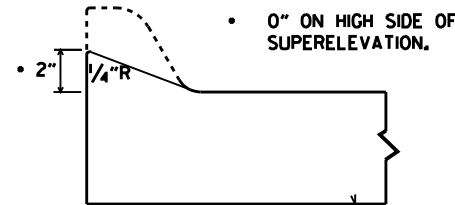

NOTE: USE MODIFIED CURB AS SPECIFIED ON STD. DR-1. COMPENSATION FOR MODIFIED CURB WILL BE CONSIDERED INCLUDED IN THE PRICE BID FOR THE TYPE OF CURB OR CURB AND GUTTER SPECIFIED.

DETAILS OF MODIFIED CURB

| DATE | REVISION | DATE FILMED |
|----------|--|-------------|
| 11-29-07 | REVISED GUTTER SLOPE & MODIFIED CURB DETAILS | |
| 11-10-05 | ADDED DETAILS OF TYPE E CURBS | |
| 11-16-01 | REVISED CONCRETE CURB TYPE B | |
| 11-18-98 | REVISED MODIFIED CURB | |
| 6-2-94 | ADDED NOTE TO SPECIAL MODIFIED CURB | |
| 8-5-93 | CORRECTED GUTTER SLOPE | 8-5-93 |
| 10-1-92 | ADDED DETAILS OF GUTTER SLOPE | 10-1-92 |
| 5-24-90 | ADDED DETAILS OF MODIFIED CURB | 5-24-90 |
| 11-30-89 | VARIABLE DEPTH TYPE A & B 1 | 11-30-89 |
| 7-15-88 | REVISED MODIFIED CURB | 630-7-15-88 |
| 11-1-73 | REVISED MODIFIED CURB | 500-11-1-73 |
| 10-2-72 | REVISED AND REDRAWN | 512-10-2-72 |

ARKANSAS STATE HIGHWAY COMMISSION

CURBING DETAILS

STANDARD DRAWING CG-1